

OWNERS MANUAL

BLADE INLINE SYNEXIS SYSTEM



Contents

Welcome.....	3
Included Parts.....	3
About Synexis® Dry Hydrogen Peroxide (DHP™).....	4
Indications for Use.....	4
Legal Notice.....	4
System Specifications.....	5
Inspecting Your System.....	6
Tools.....	6
Safety + Warranty.....	7
Getting the Best Performance.....	8
Installation.....	9
Bulb Maintenance.....	11
Bulb Replacement.....	11
Sail Replacement.....	12
Troubleshooting.....	13
Replacement Parts List.....	13
Records.....	14
Warranty.....	14



Welcome

Thank you for choosing Synexis®, developers of the Dry Hydrogen Peroxide (DHP™) Blade Inline System.

Before using the DHP™ system, please take a few minutes to:

- ✓ Familiarize yourself with the Blade Inline DHP™ System
- ✓ Familiarize yourself with the installation steps and required tools
- ✓ Inspect your system and parts

Please contact your Synexis Account Representative for questions or additional information.

Included Parts

- A** Blade Inline unit (x1)
- B** UV-A Light Bulb (x1)
- C** DHP™ Technology Sail (x1)
(sealed in plastic and sold separately)
- D** Sail Holder
- E** Self-Tapping Sheet Metal Mounting Screws (x8)
- F** Mounting Template (x1)

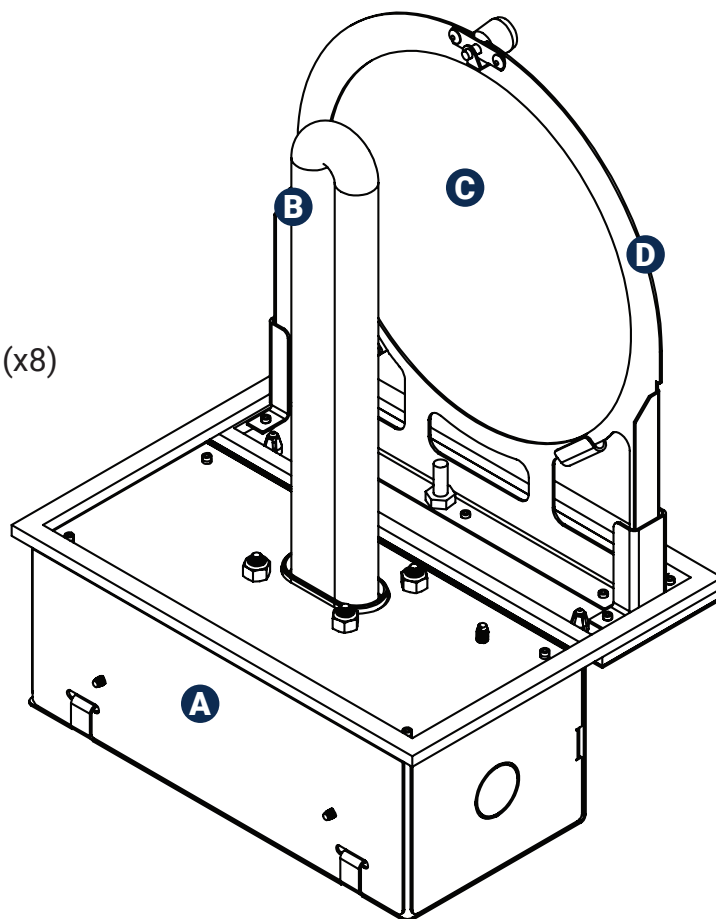
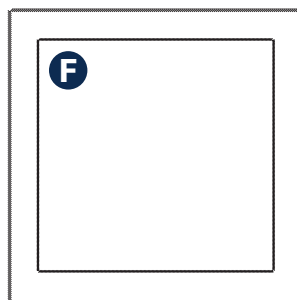

About Dry Hydrogen Peroxide (DHP™)

Synexis is the sole developer of hydrogen peroxide gas and Dry Hydrogen Peroxide (DHP™) Technology for occupied spaces. Using DHP™, our patented microbial reduction technology allows for the natural and continuous reduction of microbial contamination in occupied spaces. Synexis Microbial Reduction Systems are patented for use in the United States and around the world. By encompassing all areas of an enclosed space, DHP™ can reach the most important areas of a facility. The critical differentiator of DHP™ from other forms of hydrogen peroxide is that DHP™ can be safely delivered in occupied spaces.

Using ambient humidity and oxygen naturally present in your environment, Synexis technology creates a safe level of hydrogen peroxide (H₂O₂) gas, which reduces unwanted microbial contamination in the air and on surfaces. Because DHP™ is a true gas, it can reach the toughest and most out-of-reach areas of your facility. Dry Hydrogen Peroxide is effective because of its state of matter and method of action.

Indications for Use

This product is not sold as a medical device and is not intended to be used to diagnose any disease or condition, nor should it be used in the mitigation, treatment, or prevention of any disease or condition. The Synexis DHP™ Blade Inline device is a key component to the Synexis Microbial Reduction System.

Legal Notice

While every attempt is made to ensure the accuracy of the information contained in this manual, Synexis accepts no liability for errors or omissions, or any consequences deriving from the use of information contained herein. This Blade manual is provided “as is” and without any representation, term, condition or warranty of any kind, either express or implied. To the extent permitted by law, Synexis shall not be liable to any person or entity for any loss or damage which may arise from the use of this manual. We reserve the right at any time and without any notice to remove, amend or vary any of the content which appears herein.



Your Synexis® Blade
DHP™ System is
Assembled in the USA!

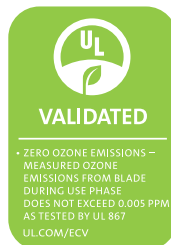

BLADE

System Specifications

The Blade is designed to fit in-line with your existing HVAC ductwork. The device can be deployed in any size duct utilizing adapters. The Blade is a completely discreet option for deploying Dry Hydrogen Peroxide (DHP™) in your occupied environment. Device installation will not impact your existing HVAC system.

Specifications	
Weight	5 lbs.
Material	18 Gauge Stainless Steel
Color	Stainless Steel
Dimensions	Width: 8.6" (21.84 cm) Height: 10.9" (27.69 cm) Depth: 6.8" (17.27 cm)

Electrical Requirements	
Input Voltage	120 VAC / 60 Hz US
Current	.56 Amps

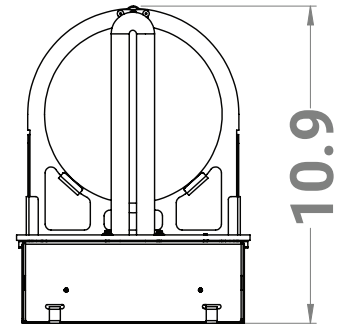
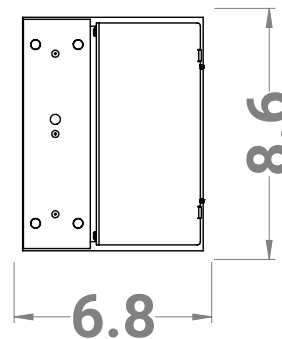
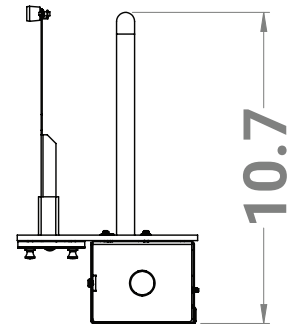
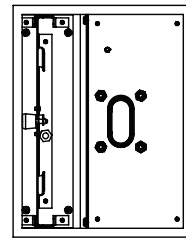
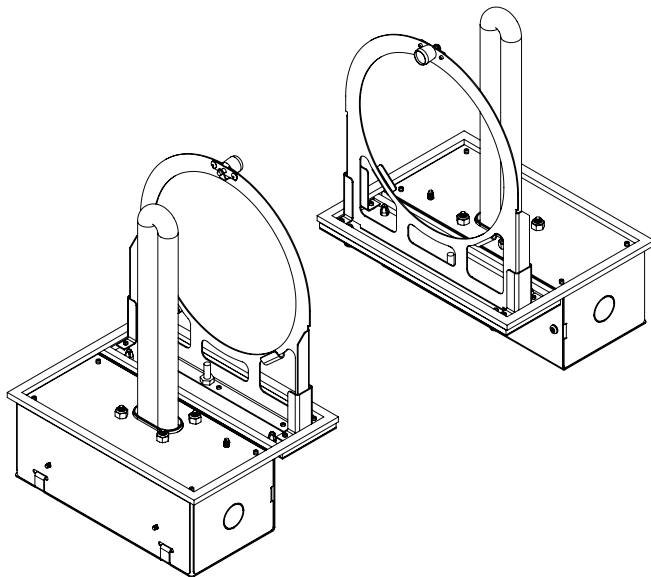

Inspecting Your Synexis System

After carefully opening the carton, unpack and inspect your Synexis Blade Inline DHP™ System.

- ✓ **No damage to the bulb**
- ✓ **No damage to the Sail holder**

DO NOT INSTALL THIS UNIT IF ANY DAMAGE IS NOTED.

If the unit is damaged, contact your distributor or Synexis Technical Support for guidance.

Prior to Installation

To ensure optimal performance, inspect ductwork prior to installation.

- ✓ **Clean diffusers and ductwork**
- ✓ **Proper level of airflow with no obstructions**
- ✓ **Dampers not located upstream within six feet of the Synexis system**
- ✓ **Dampers not located downstream between the Synexis system and diffuser**

Tools for Installation

- ✓ **Hole saw or step bit**
- ✓ **Tin snips or sheet metal shears**
- ✓ **Drill or impact driver**
- ✓ **1/4" hex driver bit**
- ✓ **Scissors for trimming duct template**

Recommended Installation Materials

- ✓ **Foil or duct tape**
- ✓ **Insulation**

Safety + Warranty

The Blade Inline DHP™ System is an electrical device. Please read, understand, and follow all safety instructions and considerations in this manual prior to use of your Blade Inline DHP™ System. Retain these instructions for future reference and take all necessary precautions to reduce the risk of fire, electric shock, explosion, or injury.

The DHP™ Limited Warranty applies only if the unit is used in accordance with these instructions. Only use genuine Synexis parts and Sails to ensure the proper functioning of your unit and to maintain your warranty.

- ✓ All HVAC, Electrical, Bulb, and Sail replacements must be performed by a qualified technician.
- ✓ It is recommended that a switch be installed to de-energize the Blade Inline unit for service and maintenance.
- ✓ Wire the Blade Inline unit in accordance to NEC standards, NFPA standards & local electrical code for 120 VAC/60 Hz power (for US). If you are uncertain how to properly wire the device, please consult or contract a qualified electrician.
- ✓ This device is designed for a closed duct system. Do not mount it near a return air opening.
- ✓ This device is designed for indoor installation only (i.e. attics, basements, etc.). It is for use in the duct work of gas fired, oil fired, electric and split system heat pump forced air systems. It is NOT designed to be mounted outside on gas fired or heat pump packaged units.
 - Split system heat pumps are systems where the air handler and the air conditioning compressor are separate units.
 - Packaged units are systems where the air handler and air conditioning compressor are built together and installed outside the building.
- ✓ Do not touch the electrical components with wet hands.
- ✓ Do not use outdoors or in a wet environment. This device is for indoor, dry location use only.
- ✓ Do not submerge the Blade Inline system in water.
- ✓ To prevent water damage or electric shock, do not mount this device under a humidifier.
- ✓ Do not use any combustible or flammable items on or near the Blade Inline system.
- ✓ Do not spill or spray any liquids or aerosols into the Blade Inline system or on the DHP™ Technology Sail.
- ✓ Do not place the Blade Inline system near a heat source.
- ✓ Do not modify or attempt to modify this product.

Getting The Best Performance From Your System

✓ **Proper number of units to cover your square footage**

The Synexis Blade Inline DHP™ system is easy to use. Make sure the proper number of units are installed for the size of the HVAC system and for the square footage of the facility. In some cases, multiple Synexis units may be necessary. Be sure to change the Sail according to the recommended replacement schedule. Leave the replacement Sail in its plastic bag and store it in a dark, dry location until you need to replace the current Sail in your Synexis Blade Inline DHP™ system.

✓ **Doors and windows closed**

The Synexis Blade Inline DHP™ system is designed for enclosed spaces, so it is important to keep all external windows and doors closed as much as possible. Open windows and/or doors can significantly reduce the efficiency of your system by allowing the DHP™ to dissipate out of the facility.

✓ **Continuous operation 24/7/365**

The Synexis Blade Inline DHP™ system is designed to operate 24 hours a day, 7 days a week. DHP™ is meant to be a continuous clean technology as opposed to a temporary clean technology. The DHP™ molecule is delicate and safe at low concentration. Producing it continuously ensures a proper equilibrium concentration in your space for effective decontamination.

✓ **Maintain a proper cleaning and replacement schedule**

Do not try to repair or adjust any of the electrical components in your Synexis Blade Inline system yourself. Contact Synexis Technical Support at 844-352-7680 for assistance and any questions you have about what is covered by your warranty.

Installation

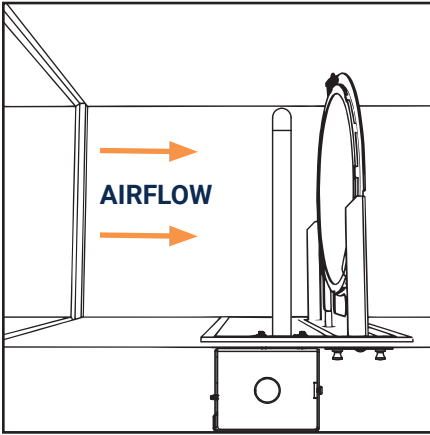

Identify a suitable location for the unit downstream from both the 'A' coil in the supply plenum and from the air filter.

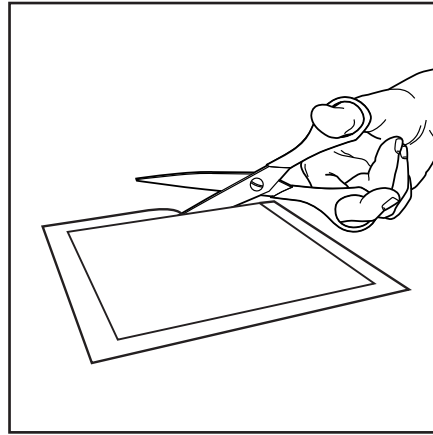

Use provided duct cutout template. Trim off outer excess of the rectangle leaving 'Cut Out Area' to be traced.

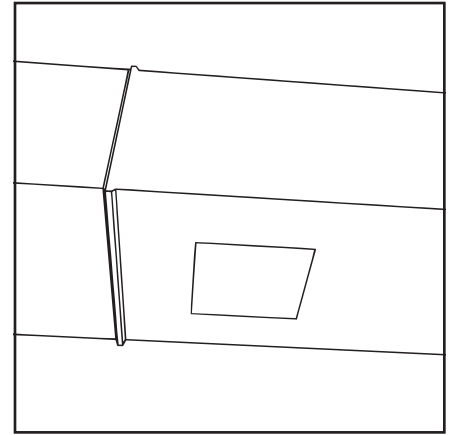

Apply the template to the section of duct that is desired for the installation.

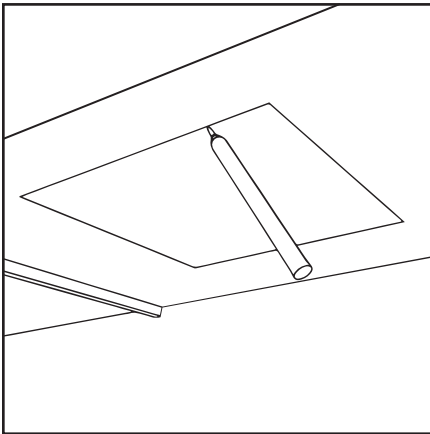

Trace the template with a marker and remove the template.

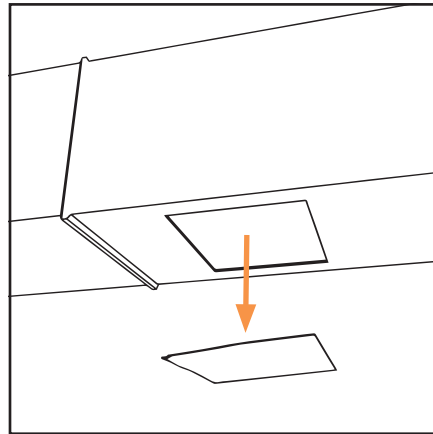

Utilizing a step drill bit, drill a hole within the area of the duct to be removed. Remove the remaining section of sheet metal from the 'Cut Out Area' using a pair of tin snips.

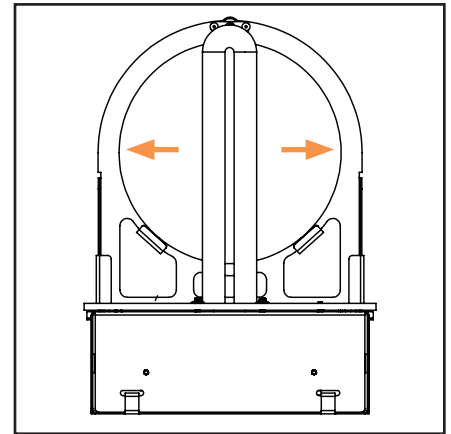

Ensure that the bulb is centered with respect to the Sail frame. Test fit the device to make sure the Sail tray is not obstructed.

Installation (cont.)

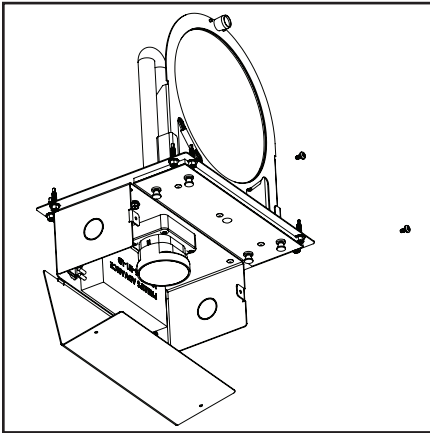

Remove the electrical box cover and the knockout from the electrical housing on the desired side for wiring purposes.

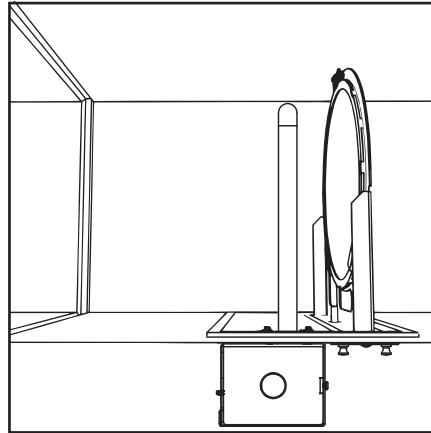

Mount the unit base to the duct using the provided eight (8) self-tapping screws and a drill or impact driver with the 1/4" hex driver bit inserted.

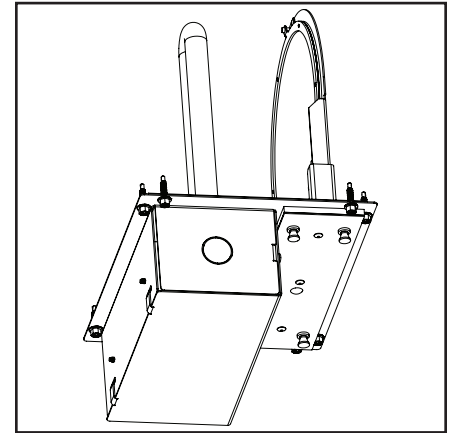

Wire the recommended switch and ballast using 120 VAC (for US). Check with NEC standards, NFPA standards and local electrical codes for the required wire type, size and connectors. Replace the electrical box cover and apply power to the unit.

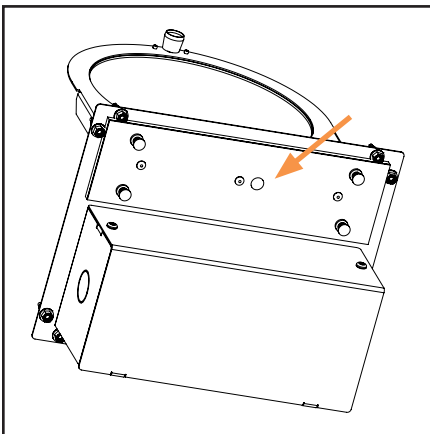

The view port on the bottom of the Sail frame should be glowing purple. This indicates power is running to the Synexis Blade Inline DHP™ system and the bulb is operational.

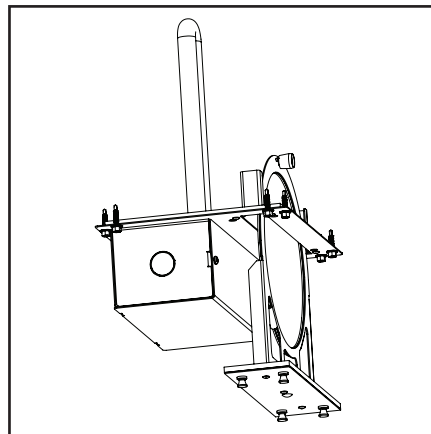

Remove the Sail (the DHP™ Technology Sail) from the plastic bag it was stored in. Locate the four (4) push rivets on the base of the unit. Gently insert the Sail with the Sail frame oriented so that the push rivets line up.

The unit is designed so that the Sail can only be inserted in the correct orientation or the push rivets will not line up.

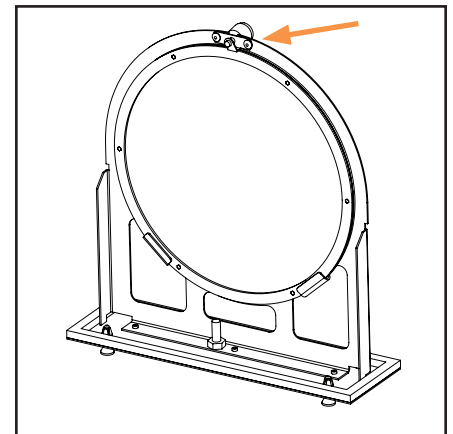

Rotate the knob at the top of the Sail frame 180 degrees so that the clip at the top of the Sail frame holds the Sail in place. After the DHP™ Sail has been installed into the Sail frame, insert the Sail frame back into the unit and attach the four snap rivets on the base of the unit.

Power on and inspect your Synexis Blade Inline DHP™ system

Bulb Maintenance

- ✓ All bulb maintenance must be performed by a qualified technician.
- ✓ Replace the bulb every 24 months to maintain the bulb's output intensity. The bulb should operate continuously.

Bulb Replacement

- ✓ **IMPORTANT:** First, de-energize your Blade Inline system.
- ✓ Slide the bulb out carefully.
- ✓ Install replacement bulb
- ✓ Gently push the bulb up until seated in the socket.
- ✓ Always wipe off the newly installed bulb to remove any oil or debris.
- ✓ **WARNING:** UV-A bulbs contain a small amount of mercury, like a typical fluorescent bulb. Check with your local waste management authority for local disposal or recycling requirements. Additional disposal and recycling information can be found at: www.lamprecycle.org.
- ✓ Power on Blade Inline system. Ensure bulb and HVAC are properly functioning.

Sail Replacement

- ✓ All Sail maintenance must be performed by a qualified technician.
- ✓ Replace your DHP™ Technology Sail after 7–14 days of operation and every 3 months thereafter.
- ✓ Synexis offers a very convenient Sail Replacement Program. Please visit us at synexis.com for the latest information on this program.
- ✓ Only use genuine Synexis Sails to ensure the proper functioning of your unit and to maintain your warranty.
- ✓ Be sure to change your DHP™ Sail according to the recommended Sail replacement schedule. This will ensure your Synexis Blade Inline DHP™ system will continue to operate at peak performance.
- ✓ Your DHP™ technology Sail comes in an opaque, food-grade plastic bag to keep it fresh until your Synexis Blade Inline DHP™ system is installed and ready for the Sail to be inserted.
- ✓ For best performance, only handle the outer plastic frame of the Sail. Do not remove the Sail from the opaque plastic bag until it is ready to use in the system.
- ✓ The Sail can be disposed of as simple trash or as recyclable plastic (frame and polyester fabric). No special handling required.
- ✓ Open four rivets on the base of your Synexis Blade Inline DHP™ system.
- ✓ Slide the Sail frame out.
- ✓ Turn knob at the top of the Sail frame 180 degrees.
- ✓ Gently remove the used Sail and replace with the new Sail.
- ✓ Seat the Sail into the two lower grooves, then turn the knob at the top of the Sail frame back 180 degrees so that the clip secures the Sail to the frame.
- ✓ Slide Sail frame back into place.
- ✓ Close four rivets on the base of your Synexis Blade Inline DHP™ system.



Troubleshooting

- ✓ All Synexis system maintenance must be performed by a qualified technician.
- ✓ If the bulb is not emitting a purple glow, verify that the power is turned on.
- ✓ If the bulb still does not light up, using a voltmeter, verify that the ballast has power on the input side. Check all electrical connections and the electrical breaker if there is no power to the ballast.
- ✓ If the bulb still doesn't light up, using a voltmeter, verify that the ballast is generating an electrical signal to the bulb. If there is no electrical signal going to the light bulb, replace the ballast.
- ✓ If the bulb still doesn't light up, replace the bulb.
- ✓ If problems persist, contact Synexis Technical Support between the hours of 8 AM – 5 PM CST Monday through Friday, at (844) 352-7680 for further assistance.

Replacement Parts List

Part	SKU
Bulb	E1006
Ballast	E2001-UN-1-0
Sail	M9017-RN-1-5

Blade Inline Records

The serial number can be found on the bottom of the unit. Please note this number in the space below and keep it for future reference.

Unit Info	
Model	
Distributor	
Serial number	

Distributor Info	
Distributor address	
Date of purchase	
Telephone	

1-Year Limited Warranty

Contact your Synexis Account Representative for any device questions, service material needs or device issues. When contacting Synexis for a system issue that is under warranty, please be prepared to provide the following:

- ✓ The unit and distributor info above
- ✓ A copy of the bill of sale
- ✓ Invoice or receipt of purchase
- ✓ An explanation of the problem or defect

This page intentionally left blank



synexis[®]

Synexis[®] LLC

11711 W 79th St | Lenexa, KS | 66214

+1 (844) 352-7680

info@synexis.com